

Oktaven von C (bzw. gleiche Tonhöhe auf unterschiedlichen Saiten)

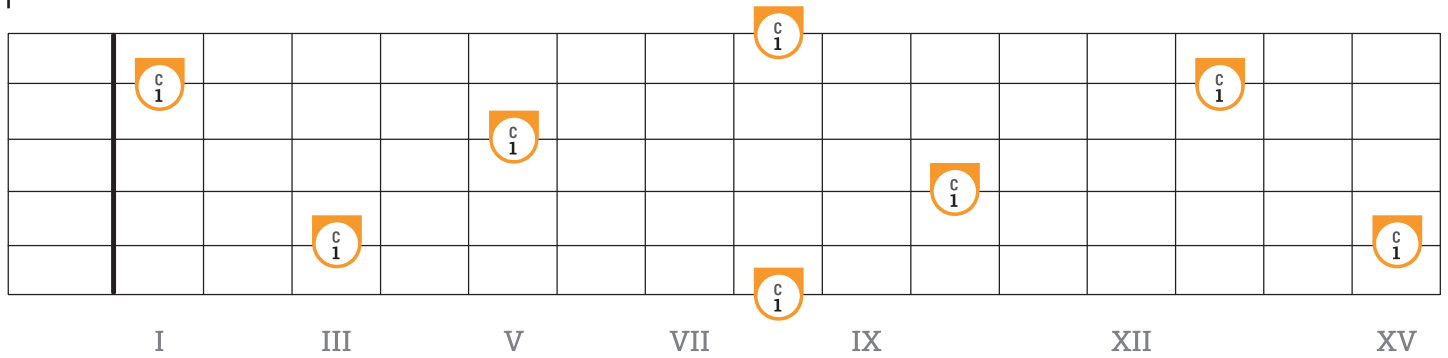

Grundton C (1) und kleine Terz (b3) / Mollterz

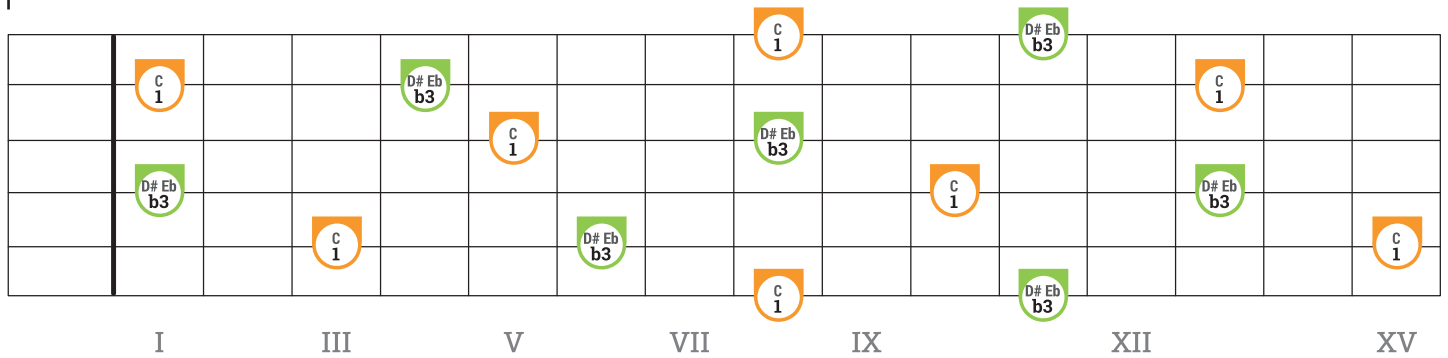

Grundton C (1) und große Terz (3) / Durterz



Grundton C (1) und Quinte (5)



Grundton C (1), verminderte Quinte (b5) und erhöhte Quinte (#5)

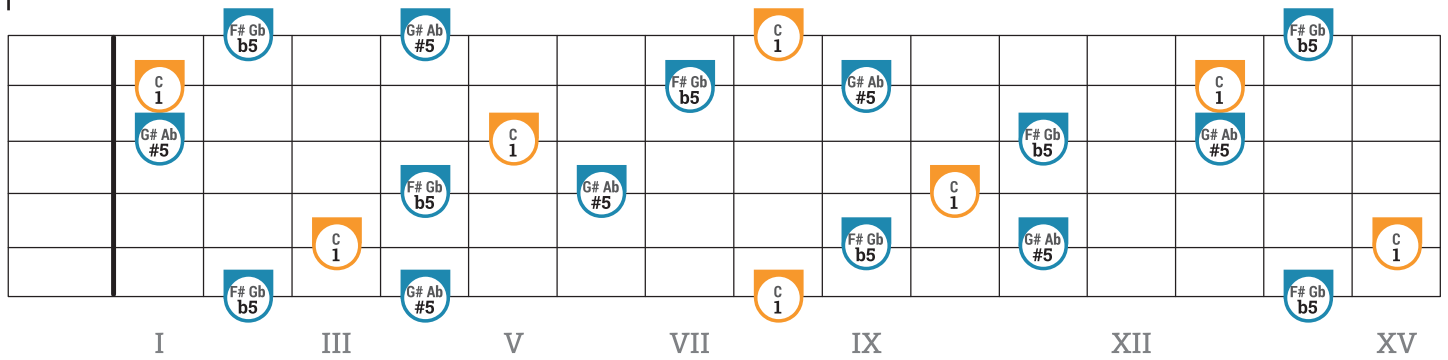

Grundton C (1), Sexte (6), kleine Septime (7) und große Septime (j7)

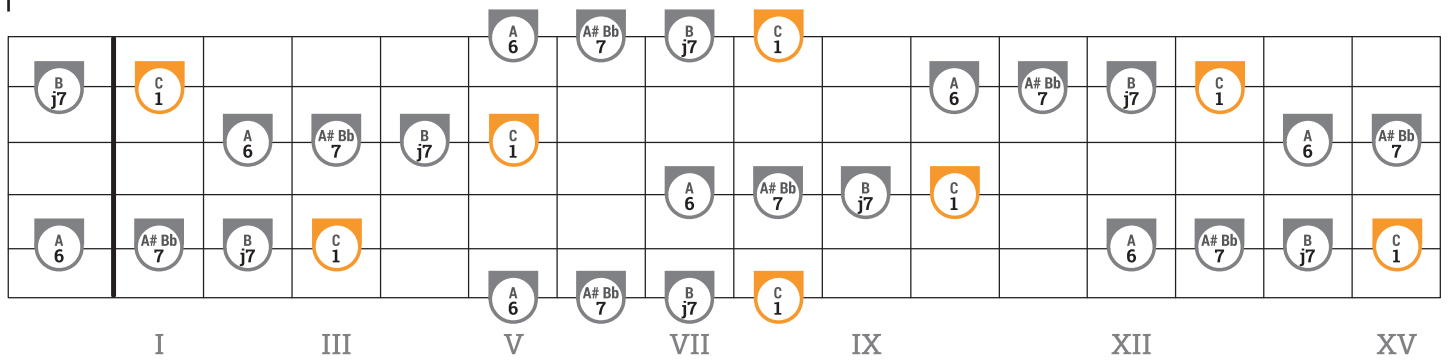

Grundton C (1) und Quarte (4)

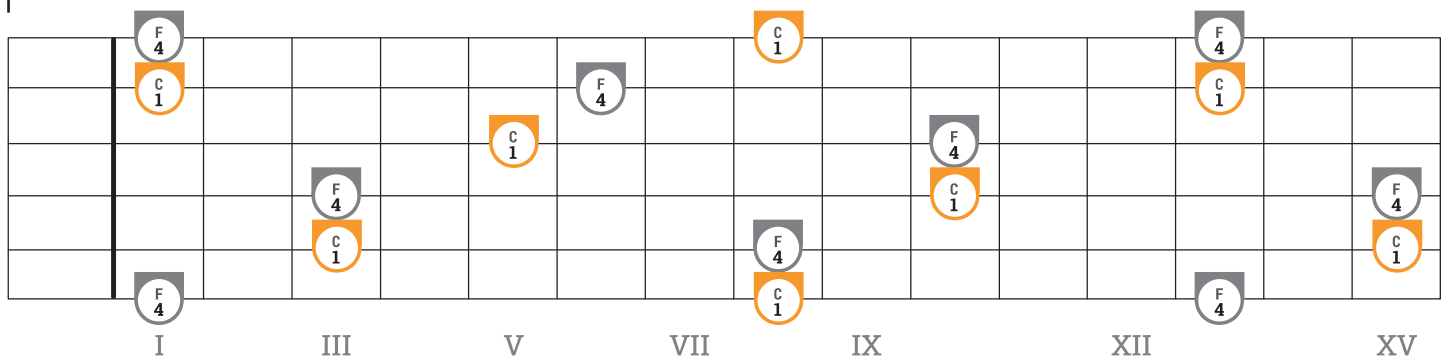

Grundton C (1), kleine Sekunde (b2) und Sekunde (2)

